

**LA-6237-MS**

Informal Report

4.3

**CIC-14 REPORT COLLECTION  
REPRODUCTION  
COPY**

UC-34c

Reporting Date: February 1976

Issued: March 1976

## Neutron Production Gas Targets

by

J. T. Martin  
R. K. Smith

LOS ALAMOS NATIONAL LABORATORY  
3 9338 00394 0615



**los alamos**  
**scientific laboratory**

of the University of California

LOS ALAMOS, NEW MEXICO 87545

An Affirmative Action/Equal Opportunity Employer

UNITED STATES  
ENERGY RESEARCH AND DEVELOPMENT ADMINISTRATION  
CONTRACT W-7405-ENG. 36

In the interest of prompt distribution, this report was not edited by the Technical Information staff.

Printed in the United States of America. Available from  
National Technical Information Service  
U.S. Department of Commerce  
5285 Port Royal Road  
Springfield, VA 22151  
Price: Printed Copy \$3.50 Microfiche \$2.25

This report was prepared as an account of work sponsored by the United States Government. Neither the United States nor the United States Energy Research and Development Administration, nor any of their employees, nor any of their contractors, subcontractors, or their employees, makes any warranty, express or implied, or assumes any legal liability or responsibility for the accuracy, completeness, or usefulness of any information, apparatus, product, or process disclosed, or represents that its use would not infringe privately owned rights.

## NEUTRON PRODUCTION GAS TARGETS

by

J. T. Martin and R. K. Smith

### ABSTRACT

A chronology of neutron production gas target techniques used at the Los Alamos Scientific Laboratory's Van de Graaff facility is given, together with detailed descriptions of recent advances.

LOS ALAMOS NATL. LAB. LIBS.

3 9338 00394 0615

The parameters for a useful neutron production gas target are:

1. The areal density of the target gas,
2. The number of incident particles entering the target, and
3. The energy of the incident particles.

A detailed discussion of these parameters is given in Ref. 1.

The areal density can be calculated from temperature, pressure, and target cell length, and corrections made for beam heating as discussed by D. K. McDaniels et al.<sup>2</sup>

The number of incident particles is measured by having the gas target act as a Faraday cup. A collimator\* and electron barrier upstream will assure that all the measured incident beam passes through the target gas. If the collimator is insulated so that its beam current can be read, it becomes a useful focusing tool. It is also useful if the collimator is removable so that it can be exchanged for different aperture openings. The electron barrier

should be insulated to allow the application of a negative potential of several hundred volts. The electron barrier's function is to repel backstreaming electrons produced in the entrance foil of the gas target, which would appear as additional protons of incident beam.

The energy of the incident particles will be well known up to the entrance foil from accelerator machine parameters, but needs to be corrected for the energy loss and straggling in the entrance foil and the target gas. The need for thin, strong, entrance foils has been studied<sup>3</sup> and has some obvious problems. The thicker the foil, the more pressure (areal density) one can safely maintain in the target. On the other hand, the thicker foils produce more background neutrons, energy loss, and straggling, and the uncertainty in the energy of the neutron beam is increased. These variables can be handled by calculations, interpolations of existing data, or with computer codes.<sup>4</sup>

Early neutron work was done with entrance foils shellacked<sup>5</sup> and later epoxied to a stainless steel flange on the tritium cell, with the cell electrically insulated from the beam tube by Bakelite bushings.<sup>6</sup> This practice had two major drawbacks: (1)

\*Also called "defining aperture."

the epoxy and shellac provided poor thermal conductivity, which allowed the foils to be overheated and destroyed by intense beams;\* and (2) the symmetry of contact was not perfect, which would cause the foil to tear at a pressure that was considerably less than the normal yield of the foil. Later, gas targets were used in conjunction with an electron barrier and aperture similar to the one shown in Figs. 1 and 2, but the electron barriers were made of aluminum and Pyrex held together by an adhesive. On some occasions during beam tuning, if the aperture were large, the beam could strike the aluminum or Pyrex, causing spot-heating, adhesive-melting,\*\* and vacuum accidents.

Later, entrance foils were soft-soldered to the stainless steel flange of the target cell. This required, in the case of molybdenum foil, nickel plating the area of the foil to be in contact with solder, while leaving the center clear, followed by tinning with soft solder. The foil was then placed on the target and aligned so that the tinned area of the foil would not cover any part of the entrance aperture. Heat was applied to make the seal, hoping that no solder or flux would protrude within the aperture area. The only way to determine the position of the solder was to x-ray the completed target. The same problem of the nonsymmetric contact around the outer periphery of the aperture exists as with the epoxied foils.

The illustrated parts breakdown (Fig. 2) shows a newer system with the foil sandwiched between two O-rings, which gives symmetry of contact to alleviate the foil tearing due to reverse flexing. Also, since there is foil-to-metal contact outside the O-ring seal, the foil-heating problem is

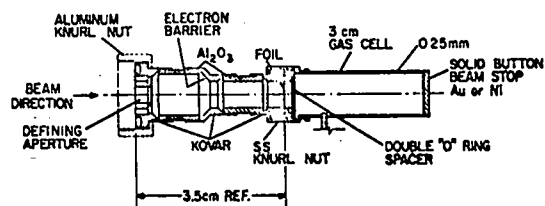

Fig. 1. Assembled target showing electron barrier and defining aperture locations.

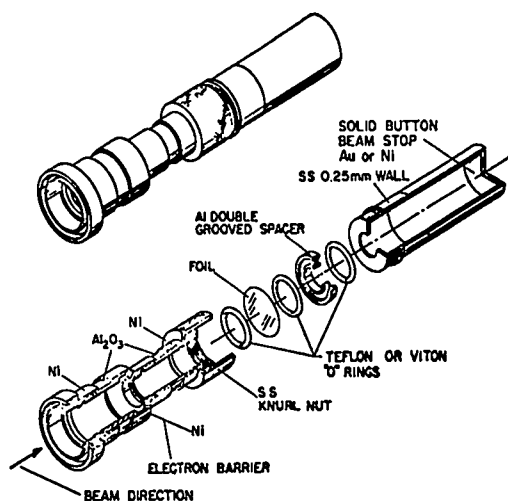

Fig. 2. Illustrated parts breakdown of double O-ring method. The double grooved spacer was to adapt this method to earlier gas cells.

alleviated. The targets that used Teflon or viton O-rings had a finite life expectancy when used with tritium gas due to damage from the low-energy beta decay.

The foil-sandwiching technique was introduced at about the same time as the aperture and electron barrier, which was made from nickel and ceramic ( $Al_2O_3$ ). These sections were silver-soldered together to provide a higher melting point to avoid vacuum accidents while tuning beam. Some problems of initially sealing these parts were encountered<sup>9</sup> due to the difference in thermal expansion coefficients between the nickel and ceramic. This was later alleviated by using Kovar in place of nickel.

\*In some cases, foil-cooling techniques have been used; see Refs. 7 and 8.

\*\*One of the more commonly used adhesives in the post-shellac era was Vinyl Acetate (Vinylite AYAC)<sup>10</sup>. (1951 literature indicates its "softening point" to be 89.6°F).

In recent years we have used 0.0762-mm-thick indium washers as a gasket material (see Fig. 3) and sandwiched the foil between two of these, much like the O-ring method shown in Fig. 2. This type of target was used for the foil studies in Ref. 3. It has also become necessary to pin the target parts, to avoid twisting and wrinkling the foil.

The use of indium washers for sealing various window materials has proved to be the best technique so far used at LASL. The use of a "biscuit cutter" (Fig. 4) for punching out indium washers from sheet stock also reduces assembly time.

The windows can be punched out with a tool similar to the "biscuit cutter," although cleaner edges are produced by compressing several layers of window material between two pieces of brass and turning them to the desired diameter in a lathe.

A quick way to leak-check an assembled target is to place the target in a small vacuum chamber with the hypodermic gas-filling tube attached to a pass-through port for applying helium pressure. The vacuum chamber can be pumped down with a helium leak detector, and any leak will show up quickly. This allows a target (gas cell) to be assembled and leak-checked in a very short time.

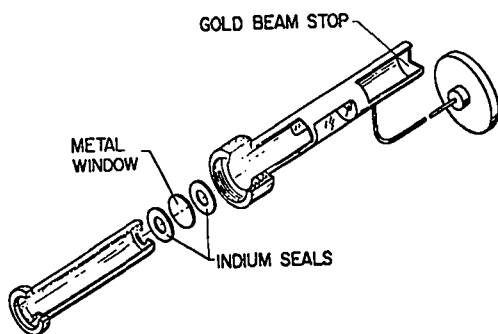

Fig. 3. Illustrated parts breakdown of double indium gasket method.

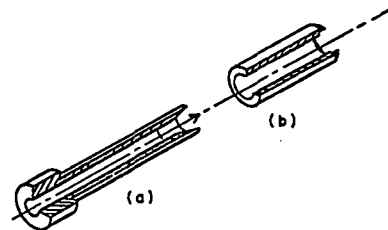

Fig. 4. "Biscuit cutter" used for punching out indium washers.

Another useful development for the  $T(P,N)^3\text{He}$  reaction is the use of isotopic  $^{58}\text{Ni}$  (99.98%) for the entrance foil and beam stop, taking advantage of the -9.4 MeV Q-value of the  $^{58}\text{Ni}(P,n)^{58}\text{Cu}$  reaction. This gives, however, a fairly prolific gamma production from the  $^{58}\text{Ni}(p,\gamma)^{59}\text{Cu}$  reaction which can easily be separated by time-of-flight methods.

The evolution of gas targets for the Los Alamos Van de Graaff facility has resulted from contributions by many people. Although no one has pursued their development as a primary goal, each has contributed some part to the targets' present level of dependability and ease of assembly. Further experimentation will no doubt result in even better techniques.

#### REFERENCES

1. J. H. Coon, "Fast Neutron Physics," J. B. Marion and J. L. Fowler, Editors, Part I, Wiley-Interscience, New York (1960).
2. D. McDaniels, I. Bergquist, D. Drake, and J. T. Martin, Nucl. Instr. and Meth. 99 77-80 (1972).
3. N. Jarmie, L. Morrison, and J. C. Martin, Nucl. Instr. and Meth. 116 451-452 (1974).
4. R. G. Clarkson and N. Jarmie, Computer Physics Communications 2 433-442 (1971).
5. J. L. Fowler and J. E. Brolley, Revs. Modern Phys. 25 2 (1956).
6. G. Jarvis, A. Hemmendinger, H. Argo, and R. Taschek, Phys. Rev. 79 6 (1950).
7. Ralph Nobles, Rev. Sci. Instr. 28 962-963 (1957).

8. Mary Jean Scott and Robert Lindgren,  
Rev. Sci. Instr. 28 1090 (1957).
9. Robert Cowan, Los Alamos Scientific  
Laboratory, personal communication.
10. P. F. Hartshorne, Los Alamos Scien-  
tific Laboratory, personal communication.